

Repowered Gearbox for Cementos Argos RD Main Mill Drive



Repowered reducer, equipped with injection lubrication system, monitoring elements, and the included flexible couplings and lubrication system.

Operational Background Cementos Argos is the number one cement and concrete producing company in Colombia, and one of the most relevant in this sector in United States, the Caribbean and Central America. In operation in Dominican Republic since 1996, actively participating in some of the country's most emblematic infrastructure projects. For some time now they have been making important improvements to its KHD ball mill.

Changes were made to the internal diaphragms, dust collectors, gas recirculation and peripheral devices, such changes made possible an increase in efficiency from 60 tph to 90 tph. The aforementioned modifications have progressively pushed the original design past its limits, causing major failures and negatively affecting its operation.

The Case Since the installation of the 60 Tph KHD ball mill in 1999, Cementos Argos has had a history of cyclical problems of failures in the primary drive. After a detailed analysis consequential to these problems, ABS proposed replacing 4 philadelphia single-stage reducers and a 2-stage Flender H2SH17 reducer as a solution.

Technical solution In order to minimize costs associated with modifications requiring a prolonged outage of operation, ABS and MGS Gears provide customized design and manufacture solutions, 100% interchangeable as well as repowered. All of which adapt to the mill's original configuration regardless of their antiquity.

In this case, due to the limitations and restrictions of the main drive (clutch, motor, and slow rotation system) foundation, the proposed solution could not modify the original position the engine or clutch.

Original dimensions of the foundation had to remain unchanged, same original Flender H2SH17 gearbox input and output shaft lines and diameters and pneumatic power connection of the EATON double drum clutch.

MGS Gears PS2-960 gearbox factory assembly process.

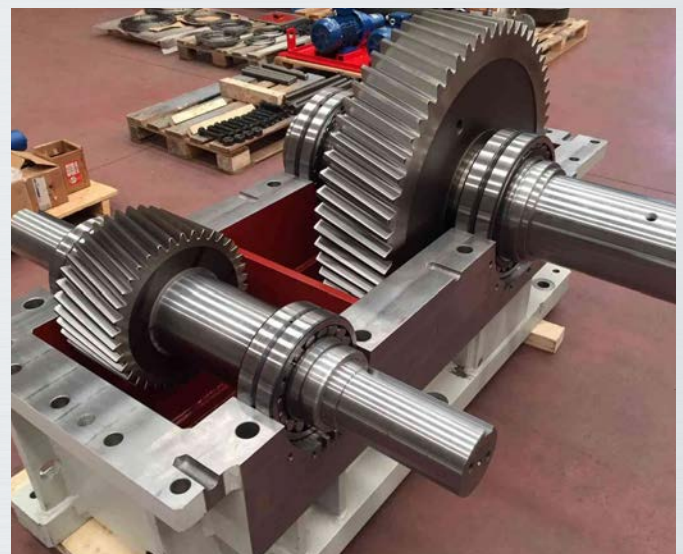

Given the suboptimal condition of the gearbox, the solution called for an increase of the gears. ABS solved this situation by means of a special design of superimposed intermediate stage which maintained the same input and output lines. This design achieved an increase in service factor from FS 1.7 to FS 2.6.

To optimize maintenance, ABS also replaced the lubrication unit for a dual-filter, dual-drive lubrication system with both stand-by and operation pumps working on parallel, making it possible to perform routine maintenance without a stop in production via the bypass system which blocks the flow.

REDUCER MGS PS2-930

PW Motor (KW)	Input speed (rpm)	Input torque (Nm)	Output speed (rpm)	Output torque (rpm)
2250	1190	18066	263.95	81450
First Stage		Second Stage		
z1/z2	39	49	17	61
Csfe	3,8	3,8	2,85	2,85
Ksfe	2,7	2,6	3	2,98
Material	18CrNiMo7-6 EN 10084	18CrNiMo7-6 EN 10084	18CrNiMo7-6 EN 10084	18CrNiMo7-6 EN 10084
Wide Tooth Hardness	185 HRc 58	185 HRc 58	230 HRc 58	215 HRc 58
HZ	79.7 N/mm2		125 N/mm3	
Quality DIN	6	6	6	6

Flender Vs MGS Comparison Table

FLENDER H2SH17

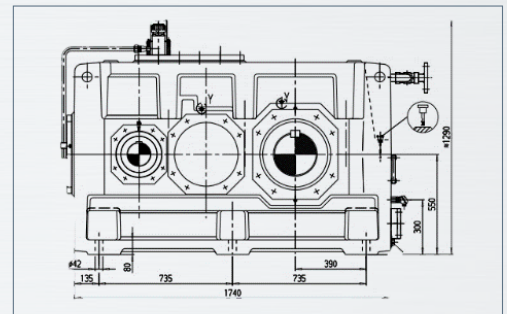

MGS PS2-930

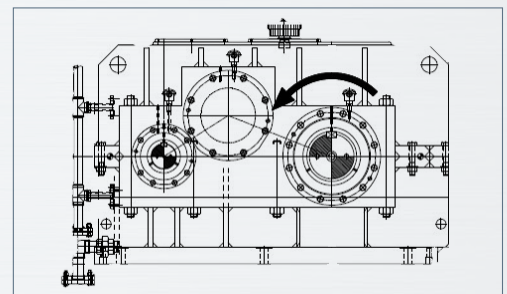

Shaft and position of the superimposed second stage in MGS model diagram

Another success story

Thanks to the interchangeable design gearbox provided by ABS and MGS Gears, Cementos Argos will not have to modify its original anchoring system. Only the installation of the electrical, pneumatic power connections and clutch disc will be necessary.

Additionally, the reducer incorporates an improved coupling, temperature sensors capable of monitoring working conditions to which it will be subjected, and electro-welded housing made of increased rigidity steel and stress relief treatment to guarantee the most extreme operating conditions.

ABS and MGS GEARS, Technical Excellence for the Heavy Industry

For over 20 years we have been offering products and engineering solutions for all types of industrial applications drives such as Ball Mills, Rotary Dryer Furnaces, Bucket Elevators, using gearboxes and components capable of adapting to any assembly requirement, space availability, and required torque and ratio, etc. We count with a wide range of special bearings and power transmission solutions for the CEMENT industry to help optimize your production processes and extend the life of your industrial equipment."